

FILL OUT AS MUCH INFO AS POSSIBLE. TAKE NOTE OF ANY ADDITIONAL OBSTRUCTIONS THAT NEED TO BE CLEARED.

<input type="checkbox"/> DOUBLE-D STEM	
A 'FLATS'	
$\phi B$	

<input type="checkbox"/> SQUARE STEM	
A 'FLATS'	
$\phi B$	

<input type="checkbox"/> KEYED STEM	
$\phi B$	
KEY	
OK	
UK	

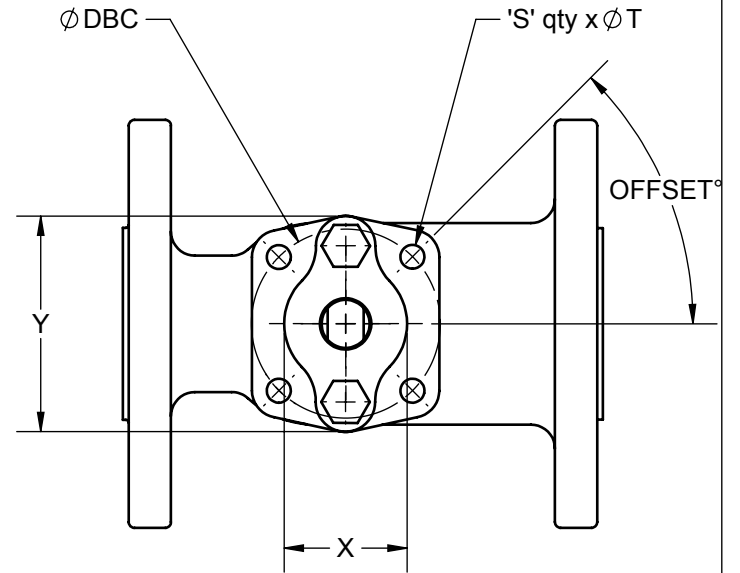
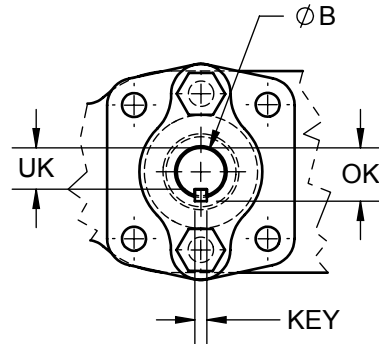
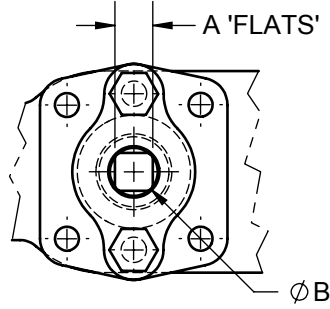
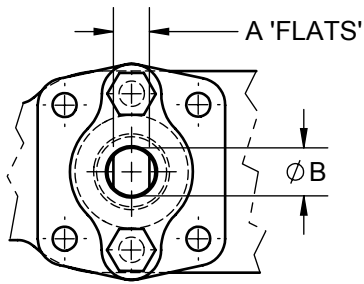

NOTHING SIMILAR TO WHAT'S SHOWN? PROVIDE A NICE SKETCH BELOW.

HOLE PATTERN. IF 'T' IS TAPPED, SPECIFY THREAD.	
DBC	
OFFSET°	
S	
T	
PACKING GLAND <input type="checkbox"/> YES <input type="checkbox"/> NO	
X	
Y	
STEM HEIGHTS	
TOTAL	
USABLE	

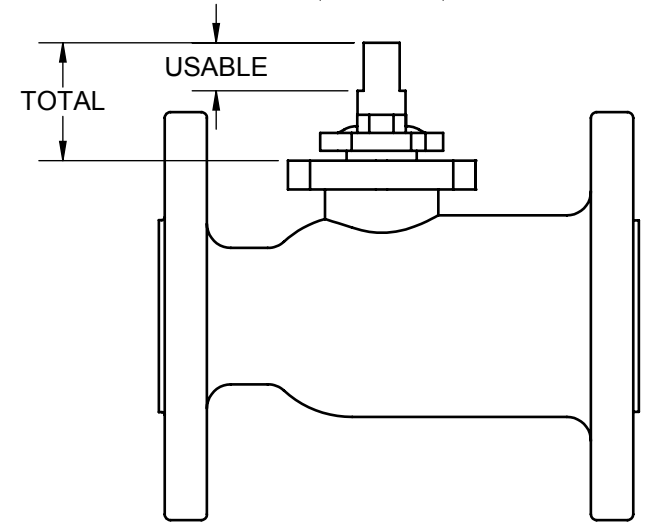

PROPRIETARY & CONFIDENTIAL: THIS DRAWING AND ITS INFORMATION ARE THE EXCLUSIVE AND CONFIDENTIAL PROPERTY OF MILL-RITE INCORPORATED AND ARE NOT TO BE DISCLOSED, DUPLICATED, DISTRIBUTED OR OTHERWISE USED WITHOUT THE WRITTEN CONSENT OF MILL-RITE. ALL RIGHTS RESERVED.

DWN BY	MONROE D.	12/29/1799	
CHK BY	MONROE D.	12/29/1799	

TOLERANCES UNLESS OTHERWISE SPECIFIED	
X.X	± .03 UP TO 30 ± 0.5
X.XX	± .01 30-120 ± 1.5
X.XXX	± .005 OVER 120 ± 4
FRACTIONAL	± 1/32 MACHINED SURFACES:
ANGLE	± 5° #error: broken link OR BETTER



BALL VALVE DIMENSIONAL INFO	
SIZE/DWG. NO.	REV.
A	
SCALE: 1:2	DON'T SCALE SHEET 1 OF 1