

FILL OUT AS MUCH INFO AS POSSIBLE. TAKE NOTE OF ANY ADDITIONAL OBSTRUCTIONS THAT NEED TO BE CLEARED.

<input type="checkbox"/>	DOUBLE-D
A 'FLATS'	
ϕB	

<input type="checkbox"/>	SQUARE DRIVE
<input type="checkbox"/> A	
ϕB	

<input type="checkbox"/>	BORE & KEYED
ϕB	
KEY	
OVER-K	

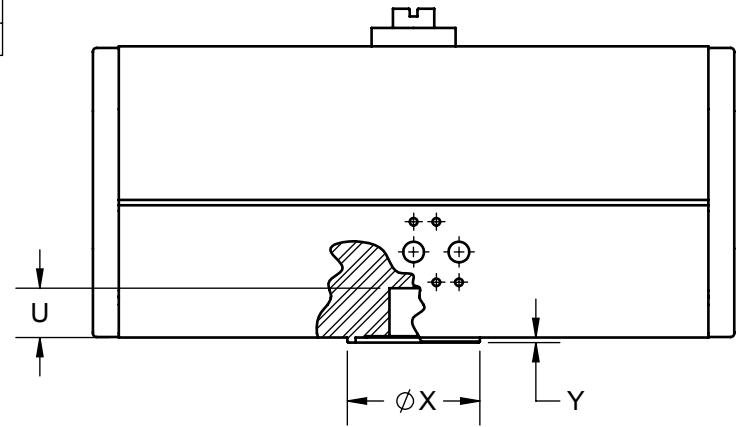
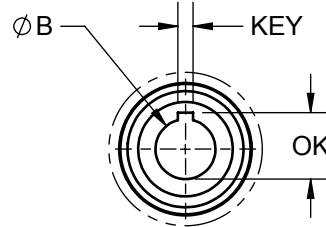
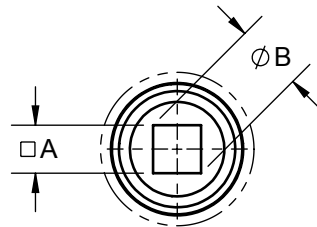
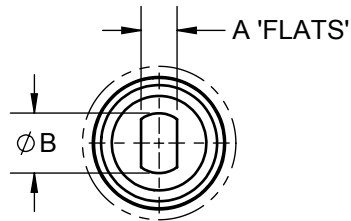

ACTUATOR IS SHOWN IN THE CLOSED POSITION. IF THE DRIVE ISN'T IN ORIENTATION SHOWN, PLEASE SPECIFY AN ANGULAR OFFSET!

NOTHING SIMILAR TO WHAT'S SHOWN? PROVIDE A NICE SKETCH BELOW.

HOLE PATTERN.	
DBC	
OFFSET°	
G	
H	
I	
ALLOWABLE DRIVE DEPTH	
U	
CENTERING RING? <input type="checkbox"/> YES <input type="checkbox"/> NO	
X	
Y	

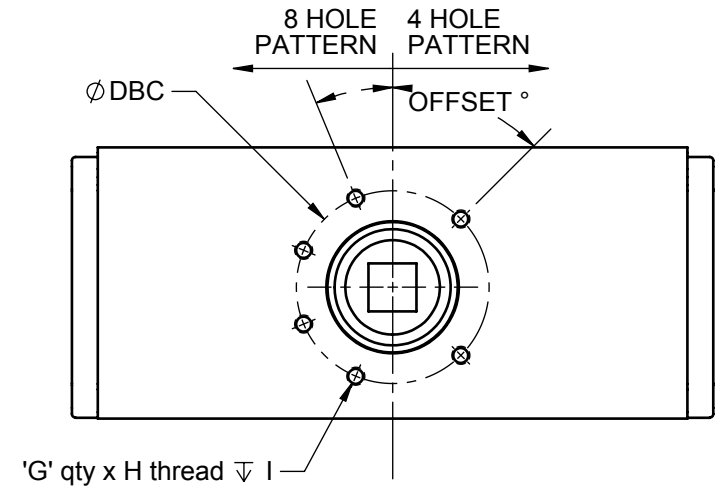

PROPRIETARY & CONFIDENTIAL:
THIS DRAWING AND ITS INFORMATION ARE THE EXCLUSIVE AND CONFIDENTIAL PROPERTY OF MILL-RITE INCORPORATED AND ARE NOT TO BE DISCLOSED, DUPLICATED, DISTRIBUTED OR OTHERWISE USED WITHOUT THE WRITTEN CONSENT OF MILL-RITE. ALL RIGHTS RESERVED.



DWN BY	MONROE D.	4/10/2015	
CHK BY	MONROE D.	4/10/2015	

TOLERANCES UNLESS OTHERWISE SPECIFIED			
X.X	± .03	UP TO 30	± 0.5
X.XX	± .01	30-120	± 1.5
X.XXX	± .005	OVER 120	± 4
FRACTIONAL	± 1/32	MACHINED SURFACES:	
ANGLE	± .5°	#error: broken link	OR BETTER

ACTUATOR, PNEUMATIC DIMENSIONAL INFO	
SIZE/DWG. NO.	REV.
A	
SCALE: 1:4	DO NOT SCALE
SHEET 1 OF 1	